

SENSOR SIZE

SUPER 35mm
27.81mm Diagonal

HIGH SPEED

up to
240fps
2K / HD

INTERNAL NDs

2 / 4 / 6
stops

RATED ISO

EI **800 / 5000**
Dual Base Sensitivity

RECORD FORMAT

AVC-HD

LATITUDE

14 stops

LUTS

REC 709

GAMMA

V LOG

DIMENSIONS

LENGTH 170mm
WIDTH 100mm
HEIGHT 133mm

WEIGHT

1.2 kg

**4K, 2K
HD**

**EF
MOUNT**

**SD
XC
MEDIA**

Panasonic

AU-EVA1

Designed by Canon based on feedback over the last five years since the EOS C300 was announced, the EOS C700 FF Camera is the Full Frame flagship digital cinema camera in Canon's Cinema EOS lineup.

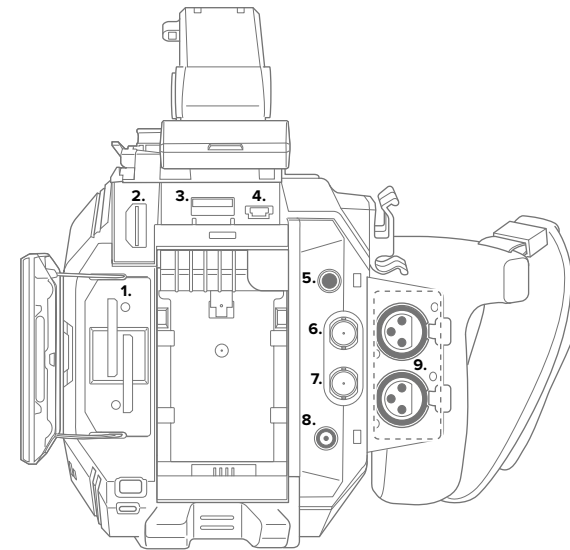

INPUTS / OUTPUTS

1. SD CARD SLOT 1 + 2

Slot for SDXC / SDHC card

2. HDMI OUT

Type-A 19-pin HDMI connector. Capable of video signal output at up to 4096 x 2160 pixels

3. USB HOST

Type-A, 4-pin USB for Wireless Module (AJ-WM50) (Optional)

4. SERVICE USB

Maintenance terminal

5. HEADPHONE

Ø3.5mm stereo mini-jack

6. SDI OUT

1.5 or 3G HD-SDI signal, up to 4096 x 2160 25p/30p resolution

7. TIMECODE

BNC jack, TIMECODE input & output

8. DC IN

12V DC mains power in.

9. AUDIO IN 1 + 2

2x XLR 3 pin inputs, 48 kHz / 16 bits. Selectable between MIC & LINE

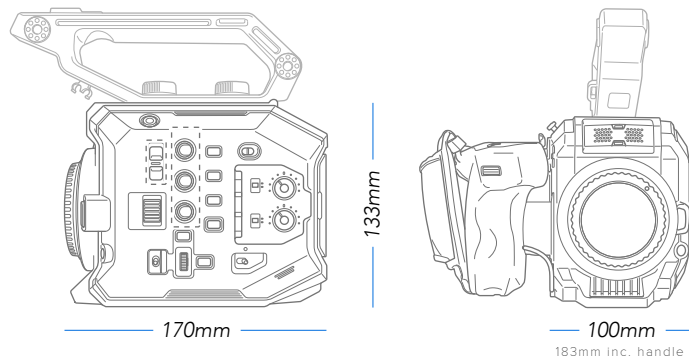

Canon

