

SENSOR SIZE

FULL FRAME
38.1mm x 20.1mm

HIGH SPEED

up to
168fps
2K Crop / HD, S-35, 10 bit
ProRes 4:2:2

INTERNAL NDs

2 / 4 / 6
8 / 10 stops

RATED ISO

EI 800

RECORD FORMAT

X-AVC
MP-4 AVC/H.264
**APPLE PRORES
RAW***
*with CODEX recorder

LATITUDE

15 stops

LUTS

REC 709 / 2020
HDR: ST2084
CUSTOM 3D

GAMMA

CANON LOG3
CANON LOG2
WIDE DR

DIMENSIONS

LENGTH 327mm
WIDTH 167mm
HEIGHT 157mm

WEIGHT

3.4 kg

**4K, 2K
HD**

**PL
MOUNT**

**CFAST
MEDIA**

Canon C700FF

Designed by Canon based on feedback over the last five years since the EOS C300 was announced, the EOS C700 Camera is the Super-35 flagship digital cinema camera in Canon's Cinema EOS lineup.

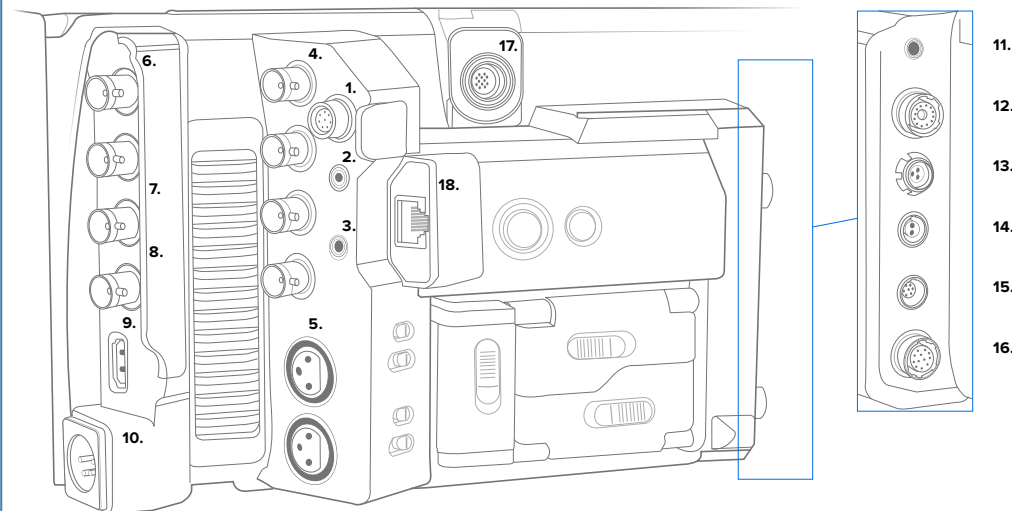

INPUTS / OUTPUTS

1. REMOTE B

For the optional RC-V100 Remote Controller

2. REMOTE A

Ø2.5mm stereo sub-mini jack

3. HEADPHONE

Ø3.5mm stereo mini-jack

4. SDI OUT 1 - 4

4K / 2K or HD, RAW or 3G
(YCbCr 4:2:2, 10 bit) HD-SDI signal

5. XLR 1 + 2

XLR 3-pin jack, balanced

6. MONITOR OUT 1 + 2

2K / HD 3G HD-SDI YCbCr 4:2:2, 10 bit signal

7. GENLOCK / SYNC OUT

BNC jack, GENLOCK setting: input only;
SYNC OUT setting: output only, tri-level HD signal

8. TIMECODE IN / OUT

BNC jack, TIMECODE input & output

9. HDMI OUT

HDMI output only, In REC-709/2020,
SMPTE ST 2084 LUTs

10. DC IN

XLR 4-pin male: 12 V DC, max 10 A
(acceptable range: 11.5 V to 20 V DC)

11. MIC IN

Ø 3.5mm stereo mini-jack

12. VIDEO

For the V70 OLED EVF

13. 24V OUT

Fischer 3-pin: 24 V DC, 2.0 A

14. 12V OUT

LEMO 2-pin: 12 V DC, 2.0 A

15. CTRL

For the optional OU-700 Remote

16. LENS

Supplies power to ENG-style lens's drive unit.

17. SYSTEM EXT.

Canon proprietary connector for
optional accessories

18. ETHERNET

Connect camera to a network device via ethernet
cable. Gigabit Ethernet (1000BASE-T) compatible

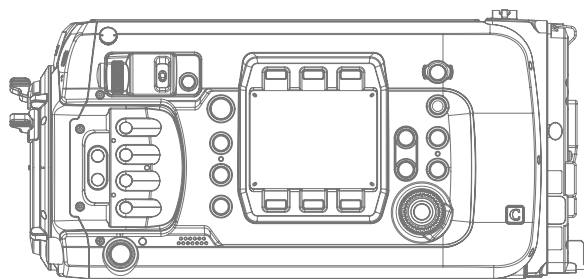

327mm

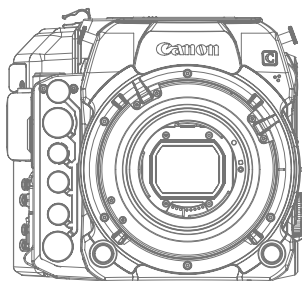

167mm

157mm

ema

